

# Installing a Panel Channels® System on a Wood Frame Structure

(Concrete, Stucco, Brick, and Concrete Block – See Instructions at end of this installation)

## **Step 1, assemble the tools that will be required to successfully complete the installation.**

Battery or electric drill.

Socket wrench set or open end wrenches, 1/2" socket or open end for driving 5/16" lag bolts.

Tape measure.

Level – Minimum 2 foot, 4 foot recommended.

5/16" or 3/8" drill bit - shank clearance drill for 5/16" lag bolt, building surface material clearance holes.

7/32" drill bit – pilot hole for 5/16" lag bolt (installation of lag bolt without pilot hole will cause splitting).

Pencil.

Step ladder – recommended 6 foot.

Powered circular saw (skill saw) – (optional, required if installer plans to cut storm panel to size).

Stud Finder (Optional – only if attaching lower Panel Channel® to studs rather than the lower window "sill").

Leather gloves.

Eye protection.

## **Step 2, we will discuss the fasteners required, including the fasteners included in your system and the fasteners you will be required to purchase after determining the correct lengths.**



Illustrated is a 5/16" steel lag bolt (stainless or galvanized) – Hex head, requires 1/2" socket / wrench. The 5/16" lag bolt will be the preferred fastener for the installation. A number of installers prefer 3/8" lag bolts, both sizes will be sufficient for the install and the apertures (holes) in the Panel Channels® will accommodate both sizes. The fasteners you will require are listed below:

Two (2) – 1 1/2" lag bolts to secure upper and lower Panel Channels® to storm panel (included in package).

Six (6) or more - 4" to 6" mounting lag bolts to secure upper and lower Panel Channels® to building (not included). Note: the method for determining the proper length of mounting lag bolts will be covered during installation.

Eight (8) - 5/16" washers for mounting lag bolts and upper and lower storm panel securing (included in package).

## **Step 3, a short summary of the installation, including the most critical step, the installation of the lower Panel Channel® and the less critical step of installing the upper channel.**

For wood construction you must ensure that the fasteners are securely anchored to solid wood framing, not whatever siding is in place. Solid wood framing includes the sill, the studs under the window, the double jacks on both sides of the window opening, and the solid header beam above the window.

Fig. F1, illustrates a **Typical Rough Frame Window Opening**.

The lower Panel Channel® will be securely fastened to the window "sill". Depending upon the type of construction, this "sill" will be a single 2" x 4" lumber member (illustrated in Fig. F1), or two (2) 2" x 4" lumber members sandwiched together (not illustrated). We will proceed with the idea that the "sill" is a single 2" x 4" lumber member.

Following the installation of the lower Panel

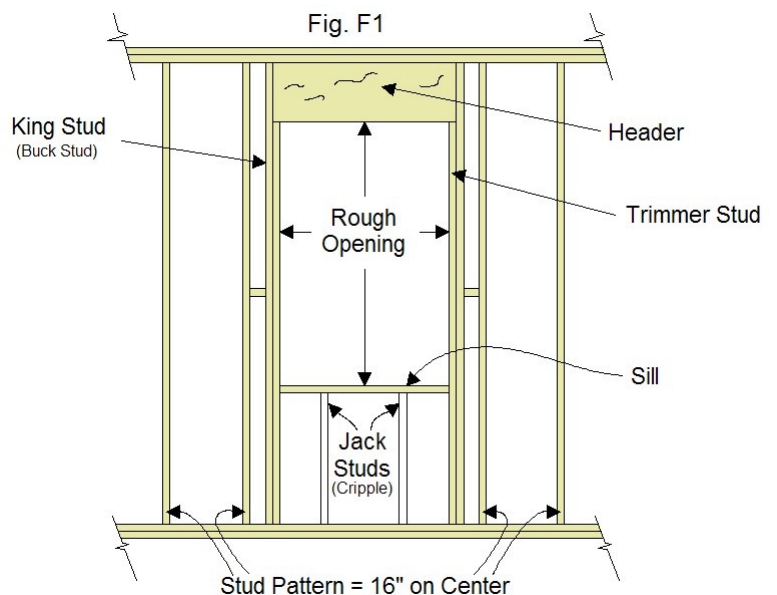

Channel<sup>®</sup> to the "sill", the installation of the upper Panel Channel<sup>®</sup> to the "header" as illustrated in Fig. F1 and Fig. F2, will be simplified and less critical due to the large surface and size of the "header" above the window opening.

Fig. F2 and Fig. F3 further illustrate the relative surface size of the "sill" as compared to the surface size of the "header".

#### **Step 4, locating the "sill" framing member beneath the window opening, supporting the window.**

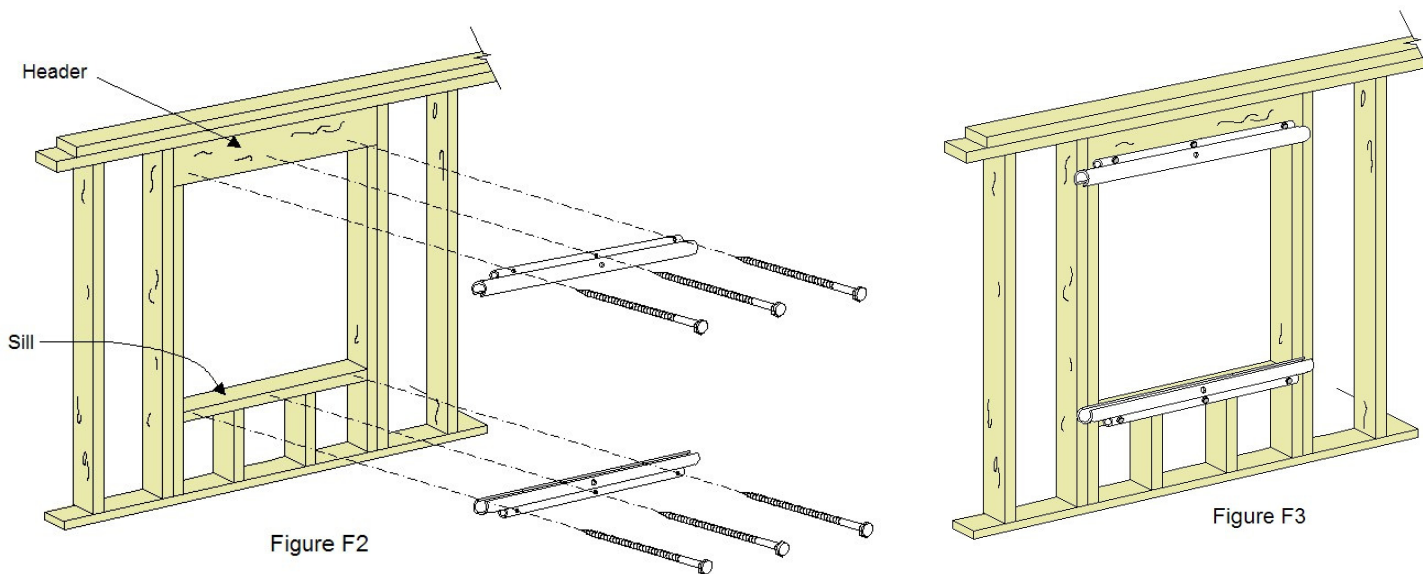

As stated, the installation of the lower Panel Channel<sup>®</sup> is the most important installation step in insuring a dependable foundation for the storm panels. The installation of the lower Panel Channel<sup>®</sup> will require locating the lower "sill" below the window opening (see Fig. F1 and Fig F2).

A recommended method for determining the location of the "sill" is to drill a small hole, approximately 7/8" below the window frame at the center of the window opening. If the drill hits solid wood after drilling through the outside surface material, (vinyl siding, wood siding, etc.) the relative location and level of the "sill" has been located, providing the solid framing member necessary to install the lower Panel Channel<sup>®</sup>. Trial and error may be required to find the solid "sill" behind the outside surface of the building. Once the distance from the bottom of the window opening to the solid "sill" under the window has been found, we move to the next step.

#### **Step 5, determining the proper length of the "mounting lag bolts" that will be used to secure the upper and lower Panel Channels<sup>®</sup> to the framing above and below the window to be protected.**

The length of the "mounting lag bolts" will be a combination of three (3) measurements. The combination will include (1) the thickness of the Panel Channel<sup>®</sup> mounting member, approximately 1 3/8" (provision for washer), (2) the thickness of the outside decorative material (vinyl siding, wood siding, etc.), and (3) add from 1 1/4" to 1 1/2" to the length of the "mounting lag bolts" to insure a substantial and secure attachment to the "sill".

The following example illustrates the combination: (1) Thickness of Panel Channel<sup>®</sup> = 1 3/8". To determine (2) the thickness of the outside decorative material, measure the distance from the outside surface until the drill encounters the "sill". Record the distance (2) from outside of the surface material before encountering the "sill". The final step (3) is adding from 1 1/4" to 1 1/2" for penetration and solid attachment to the "sill".

For this example we will use 2" as (2) the thickness from the outside surface to the "sill". By adding (1) the thickness of the Panel Channel<sup>®</sup> mounting member, 1 3/8", plus (2) the 2" thickness from the outside to the "sill", plus (3) the minimum 1 1/4" lag bolt penetration into the "sill" we would determine the approximate required length of the "mounting lag bolts".  $1\ 3/8" + 2" + 1\ 1/4" = 4\ 5/8"$  lag bolt length. From this example, the **minimum** length of the "mounting lag bolts" would be 4 1/2", the **recommended** length would be 5".

In summary, the "mounting lag bolts" must pass through (1) the Panel Channel lower member, (2) the outside surface of the building, and (3) be fastened securely to the "sill".

Big box home improvement stores and local hardware stores will carry a supply of stainless and galvanized steel lag bolts of various sizes. Purchase a quantity of lag bolts sufficient to attach the channels, using all holes provided, of the determined length of the 5/16" "**mounting lag bolts**" for each window to be protected with a Panel Channels<sup>®</sup> system. Substitution of 3/8" lag bolts will not affect the results of the installation, if by choice or by availability of fasteners. The correct pilot hole drill size for 5/16" lag bolts is 7/32", for 3/8" lag bolts the correct pilot hole drill size required is 9/32". Shank clearance holes will be 3/8".

**Step 6, before we head to out the local hardware and lumber yard to purchase the proper "mounting lag bolts", now would be a good time to determine the size of the plywood or corrugated plastic hurricane panel we need to purchase, saving a second buying trip.**

Most plywood sellers provide for cutting sheets of plywood to a requested size at no charge or a very small charge. To determine the proper "**sized**" storm panel to purchase, follow the steps below very closely. A number of other options are available and you may determine the size of your storm panel by other means if desired. The following steps have simplified the process for many of our customers.

1. Above the window opening, drill a small hole approximately 1 ½" above and in center of the window opening to insure that you have found the header, as illustrated in Figures F1, F2, and F3. This hole will be the center hole for mounting the upper Panel Channel<sup>®</sup>.
2. You have now determined the center hole below and the center hole above the window opening to be protected. These two (2) center holes will be the center mounting holes for the upper and lower panel channels. Many methods of how to determine the height of the storm panel have been submitted by customers. Our favorite method is as follows. (a) measure accurately the distance between the top and the bottom center mounting holes. (b) subtract 2 ¼" from the distance between the top and bottom center mounting holes. This distance, 2 ¼" less than the distance between the upper and lower mounting holes will provide the recommended vertical height for the hurricane storm panel, allowing ½" clearance above the panel to allow sliding the panel into and out of the Panel Channels<sup>®</sup> system.
3. The maximum recommended width of the storm panel is the length of the lower attaching member of the Panel Channel<sup>®</sup>, that is the member with a series of mounting holes. Measure this member to determine the horizontal width of the panel you wish to purchase and have sized properly.
4. After purchase of the storm panel, consult with the paint department as to a method for finishing or weatherproofing the panel prior to installation. Many exterior finishes and waterproofing materials are available. Make your choice based upon the appearance you desire in the installed storm panel. **Without some form of weatherproofing, the storm panel will warp and will not be usable a second time after enduring harsh weather conditions.**

**Step 7, assumes that the proper length "mounting lag bolts" have been purchased, and that a properly sized storm panel has been purchased. In summary, the lower channel will be installed, the upper channel will be installed and the storm panel will be inserted between the upper and lower channels.**

1. Installing the lower Panel Channel<sup>®</sup> - drill a 3/8" lag bolt **clearance hole** at the location of the lower center hole. **Do not drill into the "sill member" with the 3/8" clearance drill, the "pilot" hole requires a smaller hole.**
2. Next drill a lag bolt **pilot** hole into the "**sill member**", at the location of the lower center hole, to a depth of approximately 1 ½" into the "**sill member**".
3. Install the lower Panel Channel<sup>®</sup>, as illustrated in Figs. F2 and F3 with the hurricane panel channel facing up. Attach in the center hole only using the purchased mounting lag bolt and supplied flat washer. With the lower channel "**loosely**" installed in the center hole, "**level the channel assembly carefully**" and mark, with a pencil, the location of the other Panel Channel<sup>®</sup> mounting holes onto the building surface.

4. Drill lag bolt clearance holes in the marked mounting hole locations on the building surface, **being careful not to drill into the "sill" member**. Drill the 7/32" lag bolt pilot holes into the sill through each clearance hole, in the manner described previously.

5. Using a socket or open end wrench, attach the lower Panel Channel<sup>®</sup>, installing lag bolts with washers in all the mounting holes provided. You now have a level, installed lower Panel Channel<sup>®</sup>. Congratulations.

**Option, when required, Stud Mounted Lower Panel Channel<sup>®</sup>** - In those installations where a "Sill Mounted" lower channel is not practical, the lower channel will require installation into the wooden studs under and on each side of the window to be protected. Fig. F1 illustrates the normal location of studs below and to the sides of the window opening. To locate the positions of the studs below the window opening, use a stud finder **from the inside of the structure** to locate the studs under the window. As shown in the illustration the trimmer and king studs are located on each side of the window opening.

**Option, when required, Extended Mounted Panel Channels<sup>®</sup>** - In those installations where the window trim or exterior windowsill extends so far beyond the plane of the wall that it would interfere with sliding the chosen hurricane panel in and out of the Panel Channels<sup>®</sup> system, you will need to attach a block or board before attaching the lower Panel Channel<sup>®</sup> so that the plywood or plastic hurricane panel clears the protrusion(s).

After determining the location of the supporting and side studs, 3/8 holes will be drilled in the lower attaching member of the lower channel. Lag bolts will then be used to attach the lower channel to the window studs, properly centered and leveled below the window opening.

**Step 8, to complete the installation and protection of the window opening, the upper Panel Channel<sup>®</sup> will be installed and the hurricane storm panel will be installed.**

The installation of the upper Panel Channel<sup>®</sup> will follow the same steps involved in installing the lower channel, with the exception that the hurricane panel channel will face down as illustrated in Fig. F2 and Fig. F3. The storm panel channel of the upper Panel Channel<sup>®</sup> must be parallel to and opposite the storm panel channel of the lower Panel Channel<sup>®</sup> in order to accept the installation of the properly sized hurricane storm panel.

After installing the upper Panel Channel<sup>®</sup>, slide the waterproofed, finished, and sized hurricane panel into the channels of the upper and lower Panel Channels<sup>®</sup> until centered. In the center hole provided in the upper and lower channels that support and retain the hurricane storm panel, drill 7/32" pilot holes to accept the two (2) 5/16" x 1 1/2" lag bolts with washers, included in package, to loosely anchor the waterproofed hurricane storm panel to the upper and lower Panel Channels<sup>®</sup>. Do not over tighten these lag bolts!

## **Concrete, Stucco, Brick, and Concrete Block Installation**

The installation of Panel Channels<sup>®</sup> to a concrete, stucco, brick, concrete block, cinder block, etc. structure will involve the same basic steps detailed in this "Installing a Panel Channels<sup>®</sup> System on a Wood Frame Structure". The selection of the proper fasteners for the concrete or brick based structure will be critical to the success of the installation. This section of installation instructions will cover the selection of tools and the selection of fasteners. After selecting and purchasing the proper fasteners, the installation will basically follow the same steps outlined in "Installing a Panel Channels<sup>®</sup> System on a Wood Frame Structure". Step 1 "C" ("C" = concrete) and Step 2 "C" will now be covered for a structure of concrete, stucco, brick, or hollow concrete block. Steps 3 thru 8, detailed in this document, will provide the necessary steps to complete the installation.

**Step 1 "C", assemble the tools that will be required to successfully complete the installation.**

Battery or electric drill, or hammer drill. **Solid** concrete drilling will usually call for a hammer drill and bits. Masonry / concrete bits of the proper size to match the fasteners selected.

Socket wrench set or open end wrenches, 1/2" socket or open end for driving 5/16" lag bolts.

Wrenches or drivers to install the proper concrete fasteners selected.

Tape measure.

Level – Minimum 2 foot, 4 foot recommended.

7/32" drill bit – to provide lag bolt pilot hole for anchoring the hurricane shutter to the Panel Channel®.

Pencil.

Step ladder – recommended 6 foot.

Powered circular saw (skill saw) – (optional, required if installer plans to cut storm panel to size).

Compressed air duster to blow out concrete dust from drilled holes (hardware, photo and office supply outlets).

Leather gloves.

Eye protection.

## **Step 2 "C", we will discuss the fasteners required, including the fasteners included in your system and the fasteners you will be required to purchase after determining the correct lengths.**



Two (2) – 1 1/2" lag bolts to secure upper and lower Panel Channels® to storm panel (included in package).

Eight (8) - 5/16" washers for six (6) Panel Channels® mounting lag bolts and two (2) upper and lower storm panel securing 1 1/2" lag bolts (included in package).

Six (6) or more – Concrete anchors or fasteners selected and purchased to match the construction materials of the structure to be protected.

**IMPORTANT:** The success of this installation depends on the proper selection of fasteners to match the structure. For those installers not familiar with the variety of concrete fasteners available, the following suggestions will be helpful in determining the proper fasteners to match the construction of the building structure.

1. For a familiarization prior to purchase, an internet search using the Google® or Yahoo® search boxes will provide a comprehensive and valuable source of the various methods and fasteners available for concrete anchors. Search on the following search terms:

- \* Concrete anchors
- \* Concrete fasteners
- \* Lag screw shield
- \* Parasleeve
- \* Parawedge – **"USE ONLY ON SOLID CONCRETE – NOT BLOCK OR BRICK!"**
- \* Lead anchor
- \* Super sleeve

2. Availability in your area is the next concern. Your internet search provided the familiarity necessary to make a decision. A visit to your local big box home improvement center or hardware store would be the next step. Lowes stocks a wide variety of acceptable concrete fasteners. Other choices would be Home Depot, True Value, Ace Hardware or your local trusted hardware store. Be sure and discuss your installation with the store associate most knowledgeable in regards to fasteners. Explain that you must pass through 1 3/8" attachment member before encountering the building surface. A solid concrete surface might require a 2 1/2" to 3" fastener. Block or brick might require up to a 3" or more fastener. Your store associate will assist in determining the proper length.

3. Once the fasteners are acquired, the last considerations and purchases before installation will be as follows:

- \* Will a hammer drill be required to drill the necessary hole in the surface? (rental suggested)
- \* Purchase the size and type concrete or masonry drill bit required for the fastener hole.
- \* A compressed air duster or blow out container is a "Must" to blow dust out of the drilled holes.

Proceed now with the steps outlined in the Wood Frame Structure Installation.